

CANARY AUDIO®

Dual Mono Vacuum Tube Preamplifier

*Handcrafted in California*

CA-903

OWNER'S MANUAL

MADE IN USA

## Dear Customer:

Please allow us to take this opportunity to thank you for purchasing this CANARY AUDIO product.

We strongly recommend that you carefully study the Safety Instructions before attempting to operate the unit.

After you have finished reading the instructions, please save this manual for future reference.

### **WARNING:**

TO REDUCE THE RISK OF FIRE OR ELECTRIC SHOCK, DO NOT EXPOSE THE UNIT TO RAIN OR MOISTURE.

### **CAUTION:**

TO PREVENT ELECTRIC SHOCK, DO NOT USE THIS POLARIZED AC PLUG WITH AN EXTENSION CORD, RECEPTACLE OR OTHER OUTLET UNLESS THE BLADES CAN BE FULLY INSERTED TO PREVENT BLADE EXPOSURE.

TO REDUCE THE RISK OF FIRE OR ELECTRIC SHOCK, DO NOT REMOVE COVER (OR BACK). NO USER SERVICEABLE PARTS INSIDE. REFER SERVICING TO QUALIFIED SERVICE PERSONNEL ONLY.

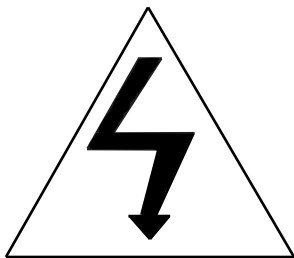

The lightning flash with arrowhead symbol is intended to alert the user to the presence of uninsulated “dangerous voltage” within the product’s enclosure that may be of sufficient magnitude to constitute a risk of electric shock to persons.

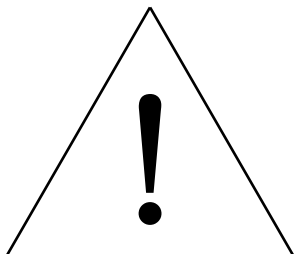

This symbol is intended to alert the user to the presence of important operating and maintenance (servicing) instructions in the literature accompanying the unit.

# **SAFETY INSTRUCTIONS**

## **Power Source:**

- The unit should be connected to an AC power source of the proper rated voltage.
- Never replace the power supply's line fuse with the one of incorrect characteristics.

## **AC Cord Protection:**

- Do not defeat the grounding or polarization feature of the AC cord.
- Make sure that the AC receptacle holds the AC cord plug firmly and securely.
- Keep the AC cord away from heating appliances.
- Never put heavy object on the AC cord.
- If smoke, malodors or noises are emitted from the unit, turn the power off and disconnect the AC cord.

## **Keep Away from Water and Moisture:**

- This unit should not be used near water.
- Keep the unit away from flower vases, bathtubs, washbowls, kitchen sinks, laundry tubs, swimming pools, etc. If liquids are spilled into the unit, serious damage could occur.

## **Ventilation:**

- Slots and openings in the chassis and in the back or bottom are provided for necessary ventilation.
- Do not place a cloth on top of the unit or block the provided ventilation slots and openings in any other way.
- Do not place the unit on a bed, sofa, rug or other similar surface which may block the slots and openings.
- Do not place the unit in a confined space, such as a bookcase or built-in cabinet, unless proper ventilation is provided.

## **Non-Use Periods:**

- When left unused for a long period of time, the unit should be unplugged from the AC outlet.

# **PROPER CARE**

## **Break-in Period:**

- As with most audio components, the CA-903 requires a “break-in” period. During this period the internal components will stabilize and reach their normal operating parameters. There are no special procedures required for this break-in period, just listening to your favorite music will accomplish this task all by itself.
- The time required to break in the CA-903 is approximately 30 to 50 hours. Upon completion of the break-in period you will hear an improvement in the overall sound quality of the preamplifier.

## **No Fingers or Other Foreign Objects:**

- Touching internal parts of this unit is dangerous and may cause serious damage to the unit. Do not attempt to disassemble the unit.
- Do not put any foreign object into the unit through the ventilation slots and openings.

## **Cleaning:**

- A regular dusting with a soft, non-abrasive cloth will generally keep the finish of the faceplate and chassis looking like new.

## **Packing Materials:**

- The original packing materials and shipping boxes are custom designed to prevent shipping damage from occurring.
- We recommend that you retain all of the packing materials and shipping boxes for your CA-903 to be covered by warranty.

## **Registration Card:**

- To ensure that your CA-903 is registered, please spend a moment now to complete and return the Registration Card.
- Save a copy of the Registration Card and the bill of sale as proof of purchase for future reference.

## **UNPACKING**

- Open the shipping boxes.
- Remove the accessories that come with the unit.
- Grasp the underside of the preamplifier and lift it straight out of the box.
- Place the preamplifier in a safe location. Remove the packing foam and the protective plastic wrapping.
- After unpacking the CA-903-L and CA-903-P, inspect them for any shipping damage and contact us immediately if any is found. Do not plug the power supply into any outlet if you find any shipping damage.
- Please keep all packing materials for future transport of your player. Shipping the CA-903-L or CA-903-P in anything other than its original boxes may result in damage that is not covered by warranty.

## **ACCESSORIES**

**The following items are included in the package aside from the main units:**

- Owner's manual
- Warranty card
- AC power cords
- DC power cables

## **PLACEMENT**

- Do not place the unit near a heating device or in a location where it is exposed to direct sunlight.
- Do not place the unit in an excessively humid or dusty location.
- Avoid placing the unit in the areas of vibration, impact or where the surface is tilted as the internal parts may be seriously damaged.
- Avoid placing the unit next to kitchen counters or other locations where it is subjected to oily fumes.
- Place the unit in a horizontal position, and do not place anything heavy on it.
- Do not place the unit on any other equipment which may become hot.

## **CONNECTION STEPS:**

1. Place the CA-903-L and CA-903-P in a rack or on a shelf. The CA-903-L and CA-903-P do not require a special rack or cabinet for installation.
2. Neatly arrange and organize wiring to and from the preamplifier and all components. Separate the AC wires from any audio cables to prevent hum or other unwanted noise from being introduced into the system.
3. Turn off any associated components prior to connecting the CA-903-L and CA-903-P. This minimizes the chance of momentary electrical surges disturbing your system.
4. Connect the supplied DC power cables to the left and right DC power output receptacles on the back of the CA-903-P.
5. Connect the other end of the DC power cables to the left and right DC power input receptacles on the back of the CA-903-L.
6. Connect the left and right analog audio outputs from all audio source equipment to any of the inputs on the back of the CA-903-L.
7. Connect the left and right analog audio outputs from the back of the CA-903-L to the inputs of an audio amplifier.
8. With the power switches in the OFF position, attach the power cords to the CA-903-P and connect them to your AC outlet.
9. Turn on the main power switches. The CA-903 will take approximately 60 seconds to initialize before it is ready for use.
10. Select the desired input signal manually using the front panel input selector knobs.
11. Use the front panel volume control knobs to set the volume to a comfortable level.

# FRONT PANEL CONTROLS

**Power LED:**  
The blue power LED will illuminate when the unit is power on.

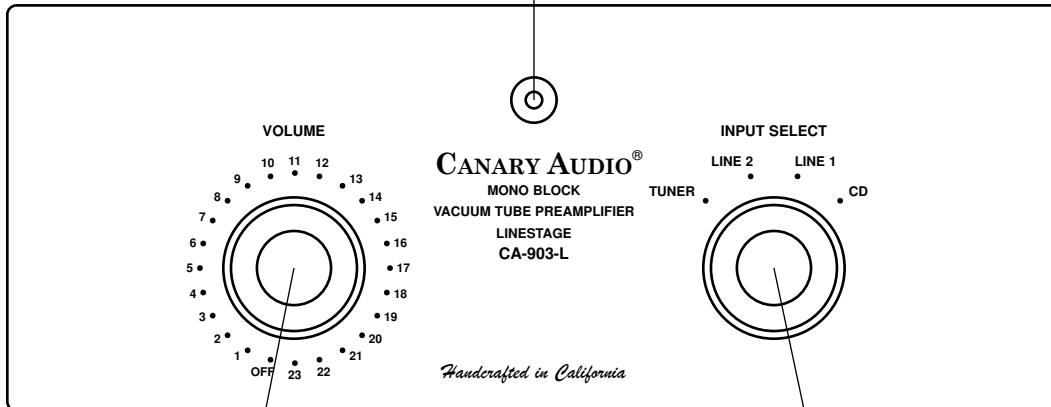

**Volume Control:**  
Adjust the output volume to the desired level.

**Input Selector:**  
Select the desired input signal from the 4 available inputs.

**Power LED:**  
The blue power LED will illuminate when the unit is power on.

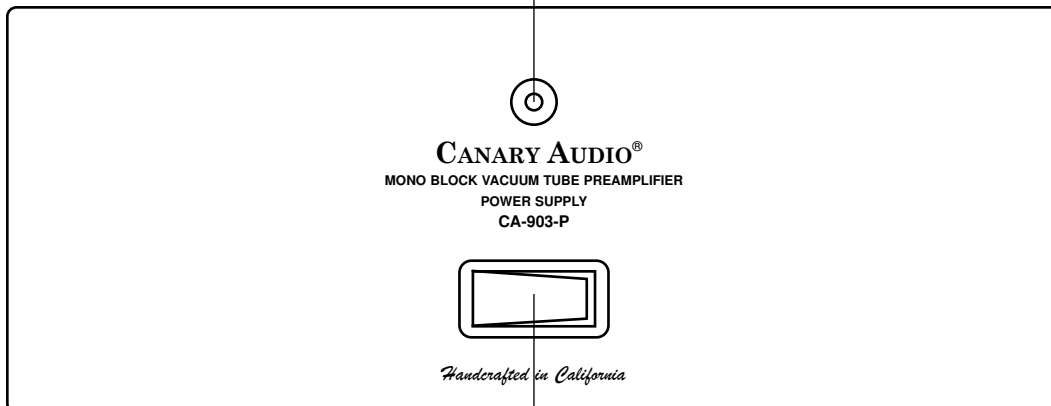

**Power Switch:**  
Power on and off both the CA-903-P and CA-903-L.

# REAR PANEL CONNECTIONS

## Analog Outputs:

Both RCA outputs are active at all time. There is no sonic difference between the two outputs.

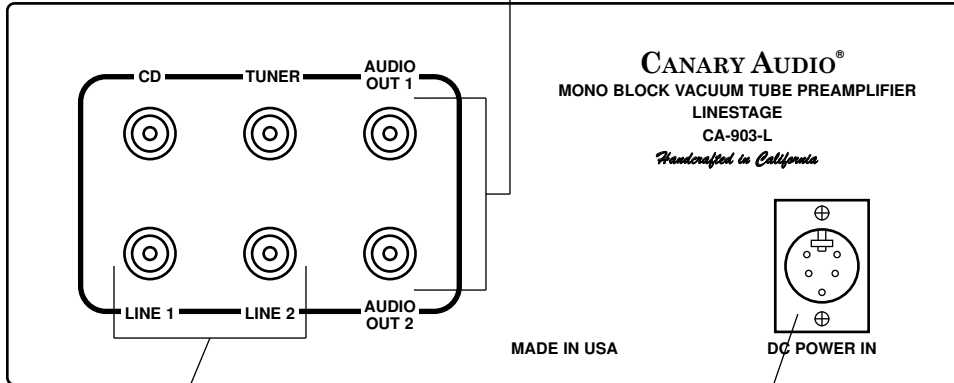

## Analog Inputs:

4 RCA inputs allow connection for up to four external sources.

## DC Power Input:

Connect to the DC power output of the CA-903-P with the supplied DC cable.

## IEC Connector:

Connect with the IEC standard 15 Amp power cord.

Ground connection for turntable or other source equipment.

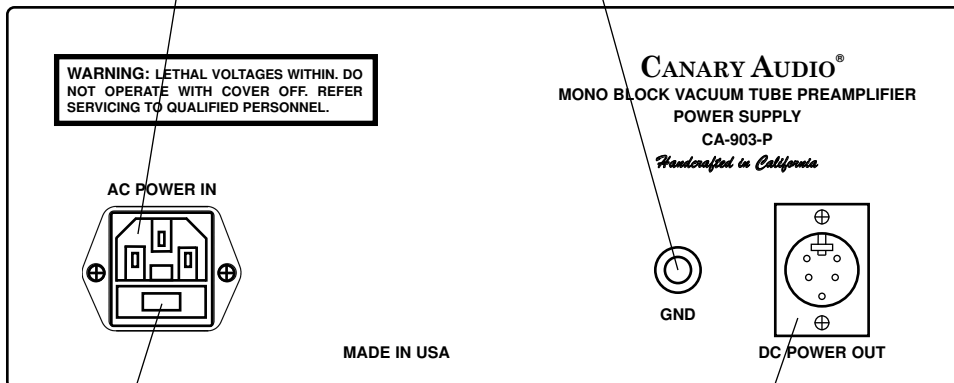

## Fuse and Fuseholder:

The fuseholder drawer houses two line fuses: one is functional and one is a spare.

## DC Power Output:

Connect to the DC power input of the CA-903-L with the supplied DC cable.

# SPECIFICATIONS

Model:	CA-903
Input Impedance:	50,000 Ohms min 100,000 Ohms max
Output Impedance:	1,200 Ohms
Maximum Gain:	12.3 dB
Frequency Response:	+/- 1 dB from 5 Hz to 118,000 Hz
Hum and Noise:	-90 dB
Maximum Output Voltage before clipping:	43.9 Volts
Total Harmonic Distortion:	< 0.01%
Power Consumption (both channels):	78 Watts (true RMS)
Tube Complement (per channel) - CA-903-L:	1-12AX7/ECC83, 1-12AU7/ECC82
- CA-903-P:	1-EF86 1-12BH7 1-5Y3
Dimensions (per channel) - CA-903-L:	11" W x 15" D x 4.75" H
- CA-903-P:	11" W x 15" D x 4.75" H
Weight (per channel) - CA-903 -L:	12 lbs.
- CA-903 -P:	22 lbs.

**Note:**

Specifications are subject to change without notice. Weight and dimensions are approximate.

# **LIMITED WARRANTY**

Canary Audio warrants to the original purchaser that each CA-903 dual mono preamplifier is free of manufacturing defects for a period of three (3) years from the date of purchase. To receive this warranty, the original purchaser must complete the enclosed Warranty Registration Card and mail it to Canary Audio within thirty (30) days from the date of purchase. Canary Audio will then validate the warranty to the original purchaser.

This warranty does not cover cosmetic damage or damage due to acts of God, accident, misuse, abuse or negligence. This warranty does not cover damage due to improper operation or maintenance, use with incompatible accessory, connection to improper voltage supply, or attempted repair, modify or upgrade by anyone other than Canary Audio or a facility authorized by Canary Audio. This warranty does not cover any damages to the vacuum tubes and does not cover normal maintenance.

Canary Audio shall not be responsible in any way for consequential or indirect damages or liabilities resulting from the use and operation of the product covered herein or resulting from any breach of this warranty or any implied warranty relating to said product. Under no circumstances does Canary Audio assume liability or responsibility for injury or damages sustained in the use or operation of this equipment or for damages to any other equipment connected to it.

During this stated period, Canary Audio will repair or replace any defective components free of charge. A Return Authorization Number (RA Number) is required before any product is returned to our factory for any reason. This number must be visible on the exterior of the shipping container(s).

Units to be repaired by Canary Audio must be sent shipping and insurance prepaid by the original purchaser in the original packing material. Canary Audio will accept no responsibility for any damage occurring to the unit that is shipped in packing material other than the original packing material. A written description of the defect and a copy of the original bill of sale should be accompanied with the returned product.

This warranty applies only to the first end-user purchaser of a CA-903 dual mono preamplifier that is purchased and used in the United States of America and is not valid for subsequent purchasers. All other warranties or conditions either written or implied are void.

## **Canary Audio**

P.O. Box 6216, Rosemead, CA 91770, USA

Telephone: (626)500-6261

[Http://www.canaryaudio.com](http://www.canaryaudio.com)